



**SERVICE & PARTS MANUAL FOR
PACIFIC SCIENTIFIC© T5 – SERIES
CABLE TENSIO METER**



TABLE OF CONTENTS

SECTION I	2
INTRODUCTION	2
WARRANTY.....	2
SECTION II	3
DESCRIPTION.....	3
GENERAL DESCRIPTION	3
DETAILED DESCRIPTION	3
Figure 2-1	4
SECTION III.....	6
OPERATION	6
PREPARATION FOR USE.....	6
OPERATING INSTRUCTIONS	6
Figure 3-1. Method of Operation – First Step.....	7
Figure 3-2. Method of Operation – Second Step	7
Figure 3-3. Method of Operation – Third Step	7
SECTION IV.....	9
SERVICE INSPECTION, MAINTENANCE, AND LUBRICATION.....	9
SERVICE TOOLS REQUIRED	9
SERVICE INSPECTION.....	9
Figure 4-2. Lubrication Chart.	10
MAINTENANCE	10
SERVICE TROUBLES AND REMEDIES.....	11
Table 4-1. Troubleshooting Chart.....	11
SECTION V	12
DISASSEMBLY, INSPECTION, REPAIR AND REASSEMBLY	12
DISASSEMBLY.....	12
INSPECTIONS AND REPAIR	13
REASSEMBLY	14
SECTION VI.....	15
CALIBRATION TEST PROCEDURES	15
GENERAL.....	15
RANGE ADJUSTMENT.....	15
<i>Note:</i>	16
TABLE 6-1. RANGE ADJUSTMENT TABLE.....	17
CALIBRATION.....	18
Figure 6-1. T5 Tensiometer Dead Weight, Calibration Set-up.....	18
<i>Note:</i>	18
TABLE 6-2. Calibration Data Table.....	20
Figure 6-2. Calibration Work Sheet.....	23
SECTION VII	24
ILLUSTRATED PARTS BREAKDOWN	24
GENERAL	24

SECTION I

INTRODUCTION

- 1-1 This manual contains descriptive data and instructions for Operating, Maintenance, Overhaul, Repair and Testing of Pacific-Scientific® Cable Tensiometer. It covers all standard models in the T5-2000, T5-8000 series. The T5-3000, T5-4000, and the T5-5000 models are obsolete for future procurement. However, other than the scissors grip, spare parts are available and repair and recalibration can be accomplished. If replacement of a T5-3000 series model is required, order the applicable configuration T5-2000 or T5-8000 series with the same dash numbers as the old configuration. The T5-5003-106-00 and T5-4008-106-00 are inactive and if a replacement is required, order a T5-8003-106-00 and T5-8008-106-00 respectively.

WARRANTY

- 1-2 All T5 series Cable Tensiometers have a warranty to the original customer for a period of (1) one year on *new* units and (6) six months for *repaired* units from the invoice date. This warranty is to ensure the cable tensiometer is free of defects in materials and workmanship under correct and normal use. The warranty can be void if the unit has been tampered, alteration, dropped or damaged by an accident.

An incorrect operation or handling that may cause an ‘overload action’ and consequently can make the unit to be “*out of calibration*”, not necessary will be repaired under warranty. Refer to section III for complete operating instructions.

The T5 series cable tensiometer is considered to be “*Out of Calibration*” when the average readings are more than (+/-) 2 readings points compared to charted readings on the supplied and unique calibration card. Refer to Section 3-2 for operating procedures and to sections 6-4 & 6-5 for calibration and test procedures.

All returns must have a Return Material Authorization (RMA) number. In order to obtain a RMA, please contact our quality department via email, jorge@optimanufacturing.com, or via fax: (787) 889-2805.

SECTION II

DESCRIPTION

GENERAL DESCRIPTION

- 2-1. The series T5 aircraft tensiometer is a small compact unit designed for determining the tension on aircraft cables. Its use permits the rigging and maintenance of cable loads at the tension specified.
- 2-2. The instruments weigh approximately between 13 and 18 ounces and the mechanism is contained in aluminum die cast case finished in black. The internal mechanism is metal with the exception of the clear dial glass.
- 2-3. The Type 5 Tensiometer is built for rugged, continuous service, but is nevertheless a precision instrument and should be treated as such. When not in use, it should be kept in the carrying case provided. With proper care and by following closely the instructions provided, it will give long and satisfactory service.

DETAILED DESCRIPTION (See figure 2-1.)

- 2-4. **SECTORS AND RISERS.** The offset in the cable is affected by passing it between two hardened pivoting steel sectors (42 and 43) and a retractable hardened steel riser (52) located midway between the sectors. The riser rests on the mainspring leaf assembly and is held in position by riser clip assembly (17). The pivoting sectors function as rollers of large diameters to span the depressions between the cable and pivot slightly caused by offsetting of the cable. The pivots are held in their outward position by sector springs (44) set in recesses in the case (49), causing the sectors to bear against sector pivot pins (41) which are a press fit into case (49).
- 2-5. **TRIGGER.** In order to pass a tight cable between the two sectors (42 and 43) and over the riser (52), the riser is retracted by lowering one end of which is attached to the main spring pivot pin (46). The free end of the mainspring leaf assembly rests on two trigger rollers (31), which are attached to lever assembly (34) or trigger lever (35, figure 7-1) of the trigger assembly (30 thru 35). The lever assembly or trigger lever project from the side of the instrument case. Opening the lever assembly or trigger lever lowers one end of the mainspring leaf assembly (16, figure 2-1) and the riser (52). Closing the lever assembly or trigger lever raises the mainspring leaf assembly along with the riser, and therefore lever raises the mainspring leaf assembly along with the riser, and therefore creates the offset in the cable. An angled flat trigger spring (29) is provided to give an over center snap action to the lever assembly or trigger lever. The photograph of the T5-2000 Series Tensiometer on the title page shows the standard lever assembly used only on this series. The T5-8000 series utilizing a mitten grip is also depicted on the title page.

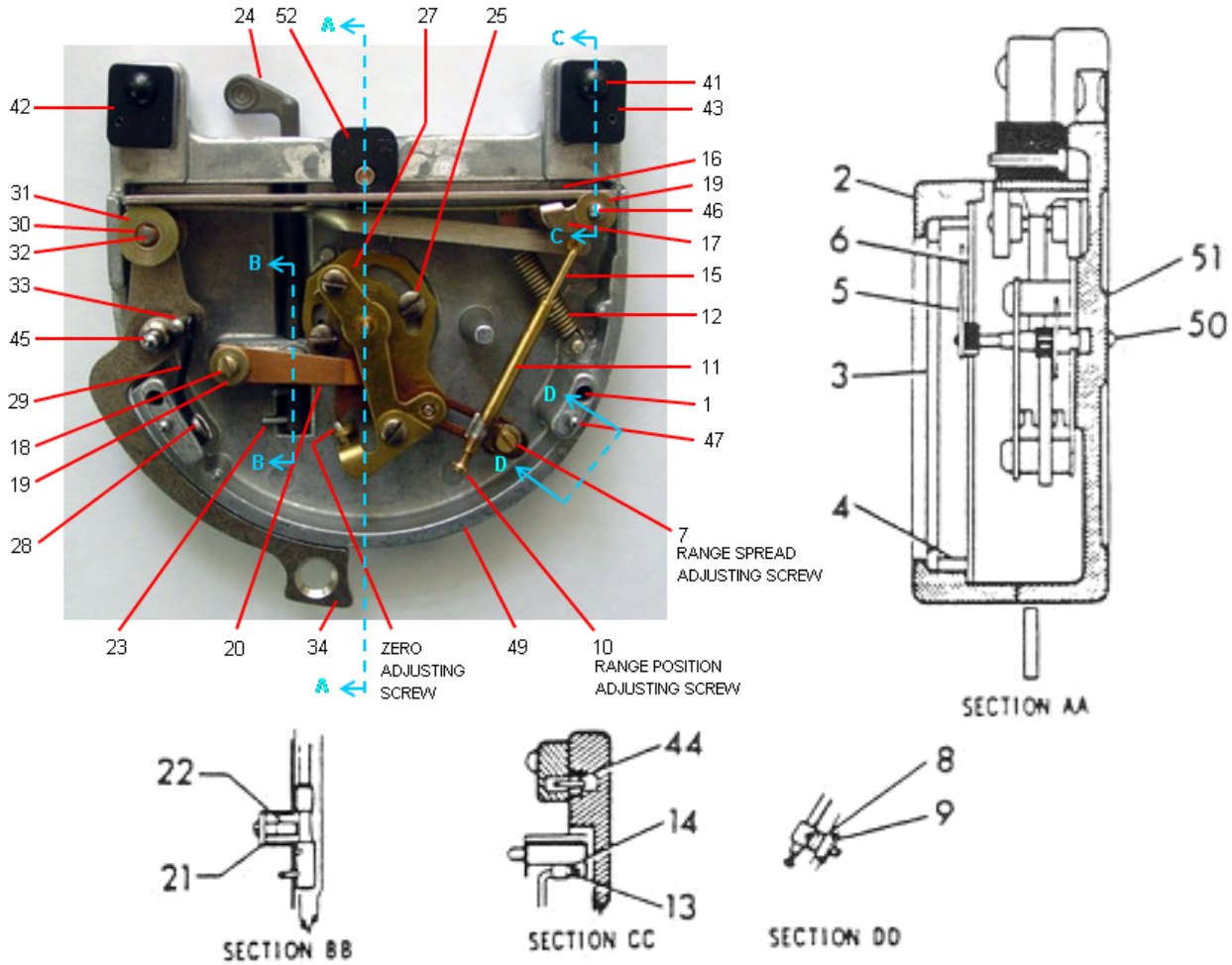

Figure 2-1

KEY TO FIGURE 2-1

1. Case Screw	19. Washer	38. Screw
2. Cover	20. Brake Spring	39. Washer
3. Glass	21. Brake Plunger Spring	40. Handle
4. Bezel	22. Brake Plunger	41. Sector Pivot Pin
5. Pointer Assembly	23. Grove Pin	42. Left Hand Sector Assembly
6. Dial	24. Brake Lever Rod	43. Right Hand Sector Assembly
7. Stop-Screw	25. Screw	44. Sector Spring
8. Spacer Washer	27. Movement Assembly	45. Trigger Pivot Pin
9. Channel Nut	28. Screw	46. Main Spring Pivot Pin
10. Screw	29. Trigger Spring	47. Dial Mounting Pin
11. Sleeve Assembly	30. Ring Lock	48. Drive Screw
12. Riser Clip Spring	31. Trigger Roller	49. Case
13. Spring	32. Roller Pin	50. Drive Screw
14. Washer	33. Trigger Spring Pin	51. Nameplate
15. Rod Linkage	34. Lever Trigger	52. Riser
16. Mainspring Leaf Assembly	35. Leaf Trigger	-
17. Riser Clip Assembly	36. Screw	-
18. Screw	37. Washer	

- 2-6. **MAINSRING.** The reaction of the cable offset bows the mainspring leaf assembly (16). An arm riveted to the fixed end of the main spring leaf assembly becomes tangent to the bowed mainspring leaf assembly, producing a substantial movement to the opposite free end of the mainspring leaf assembly.
- 2-7. **MOVEMENT AND LINKAGE.** The movement referred to in the preceding paragraph is transmitted by the linkage rod (15) and sleeve assembly (11) to the movement assembly (27). The linkage rod and sleeve assembly move as a unit, except when the pointer (5) is locked in position. The movement assembly is a self-contained brass unit comprised of a toothed segment meshing with a pinion gear on the pointed arbor. The outer end of the segment meshing with a pinion gear on the pointed arbor. The outer end of the segment consists of a slotted arm, to which the linkage rod (15) is attached. The purpose of the slot is to provide a means of adjusting the range of the Tensiometer. A hairspring is provided in the movement to eliminate backlash in the gears and to return the pointer to zero. An adjustable segment stop-screw (7) is provided to limit the travel of the segment, thus providing a more positive zero adjustment.
- 2-8. **BRAKE.** The brake lever rod (24) serves to lock the tensiometer pointer in the event that dial (6) cannot be seen when taking a reading. The lock consists of two flat bronze springs (20 and 21). The longer brake spring (20) is set to normally bear against the segment of the movement, to hold it by friction when the brake lever is in the locked position. The shorter brake plunger spring (21) is to provide a snap action to the brake lever rod. Rotating the brake lever rod (24) lifts the two springs by means of brake plunger (22), which normally rides on a recessed flat in the brake lever rod.
- 2-9. **NON-OPERATING PARTS.** The foregoing covers the operating parts of the Tensiometer. The remaining parts are the case (49) on which all the operating parts and the dial (6) are mounted, and the cover (2) into which the glass (3) and bezel (4) are fitted.

SECTION III

OPERATION

PREPARATION FOR USE

- 3-1. ***It is vital to have the correct riser mounted on the instrument.*** Refer to Table 6-2 to determine the correct riser required for the size cable to be tested. Selection of the wrong riser will give incorrect readings and may damage the tensiometer. This information is given on the calibration card for each model (see Figure 3-3). *Each calibration card is prepared for a specific Tensiometer.* The serial number, noted near the lower left corner of the calibration card, must match the serial number noted on the nameplate of the tensiometer. The use of non-matched sets will give incorrect readings and render the tensiometer out of calibration. The *brake rod* must also be checked to see that it is in the ***unlocked*** position before clamping the instrument on the cable.

OPERATING INSTRUCTIONS

- 3-2. Operate the Tensiometer in accordance with the following instructions:
- Move the lever assembly away from the case as far as possible, and place the instrument on the cable with the sectors resting against the cable. (See Figure 3-1.)
 - Close the lever assembly with the fingers of the hand in which the instrument is held. (See Figure 3-2.)
 - If the dial of the instrument is visible, take the reading and then disengage the instrument by moving the lever assembly away from the case.

Due principally to the uneven surface of the stranded cables, slight variations in readings may occur on the same cable at the same tension. If closest possible accuracy is desired take two or three readings at slightly different locations on the cable and average them.

- If it is necessary to take a reading when the dial cannot be seen, the pointer assembly may be locked in position by pushing forward the brake lever rod at the top left of the case. The pointer assembly is unlocked by returning the brake lever rod to its original position. Never lock the brake lever rod until the instrument is clamped on the cable where the load is to be measured, or a false reading will result.
- Convert the dial reading to tension in pounds by referring to the calibration chart. A typical conversion is shown in figures 3-2 and 3-3, where a dial reading of 54 points with the instrument testing a 1/16 inch cable (see figure 3-2) is converted to 150 pounds tension by referring to the calibration chart. (See Figure 3-3).

WARNING. Do not overload the instrument – that is, permit the Pointer to go beyond the “100” mark on the dial. When first applying to a tight cable, close the Trigger slowly and watch the Pointer to be sure it will not go above the “100” mark when the load is fully applied. Permanent damage may be done to the instrument when it is overloaded.



Figure 3-1. Method of Operation – First Step

**TENSIO METER
CALIBRATION CARD**

MODEL NO. T5-2002-104-00 SERIAL NO. 65477

CABLE TENSION (LBS)	RISER NOS.								
	#1	#1	#1	#2C	#2C	#3	#3		
	CABLE DIAMETERS (INCHES)								
	1/16	3/32	1/8	5/32	3/16	7/32	1/4		
30	10	14	18	10	15	17	25	0	0
40	14	19	24	14	19	21	30	0	0
50	18	24	30	18	23	25	34	0	0
60	23	29	35	22	28	28	38	0	0
70	28	34	40	25	32	32	42	0	0
80	32	39	46	29	36	36	46	0	0
90	36	43	51	32	39	39	49	0	0
100	39	47	56	34	42	42	52	0	0
110	42	51	60	37	46	45	54	0	0
120	46	55	65	40	49	48	57	0	0
130	49	58	69	42	52	50	60	0	0
140	52	62	72	44	54	52	62	0	0
150	54	66	76	47	57	55	65	0	0
160	57	69	80	49	60	57	68	0	0
170	60	72	84	51	63	59	70	0	0
180	62	75	87	54	66	61	73	0	0
190	65	78	90	56	68	63	76	0	0
200	68	81	94	58	71	65	78	0	0
220	0	0	0	61	75	68	82	0	0
240	0	0	0	64	78	72	85	0	0
260	0	0	0	68	82	76	88	0	0
280	0	0	0	71	86	79	92	0	0
300	0	0	0	75	90	82	96	0	0

Figure 3-2. Method of Operation – Second Step

Figure 3-3. Method of Operation – Third Step

- 3-3. It should be remembered that the tension on the control cables of an aircraft (*unless the aircraft is equipped with automatic cable tension regulators, refer to section 3-4*) varies with temperature. For instance, cables may be rigged at 50-pounds tension when the temperature is 24 degrees C (75 degrees F). Later the cables may be checked when the aircraft has been standing in the direct sunlight at a temperature of 38 degrees C (100 degrees F) and found to have a tension of 100 pounds or more. Under these conditions, reports are sometimes received that the Tensiometer is inaccurate because the cables were known to have been originally rigged at 50-pounds. A comparatively small change in temperature will make an appreciable difference in the tension of the cables. Under these conditions, therefore, it should be assumed the instrument is accurate and the cables are under higher or lower tension, as the case may be.
- 3-4. Cable Tensiometers should not be used for adjusting the rig load in a cable system where an automatic cable tension regulator is installed. In all cases, such cable systems should be rigged by adjusting them so that the pointer on the cable tension regulator scale indicates the correct number based on the surrounding temperature, as indicated on the chart provided in the Airplane Service manual. The tensiometer may be used to check the tension obtained, but it must be remembered that the actual cable tension will vary from the nominal, depending upon the errors in the instrument itself, manufacturing tolerance of springs in the regulators, rate of the regulator spring, and condition of the control cable. Cable tension readings taken on regulated control systems by means of a tensiometer could, therefore, be misleading.

Note: *The attitude of the indicator does not affect the readings – i.e., it makes no difference whether the Indicator is in vertical or horizontal attitude, or at any point between these positions.*

SECTION IV

SERVICE INSPECTION, MAINTENANCE, AND LUBRICATION

SERVICE TOOLS REQUIRED

- 4-1. A suitable handjack is necessary as well as the regular instrument repair shop tools. Since it is necessary to press the pointed assembly onto the spindle tightly to prevent slippage when the pointer assembly snaps back accidentally, some types of pointed assembly removers are not satisfactory.
- 4-2. A suitable handjack for this purpose is illustrated in figure 4-1 and may be purchased from OPTI Manufacturing Corp., Part Number T5-AT-1.

SERVICE INSPECTION

- 4-3. When a Tensiometer is in daily use, the cover, pointer assembly, and dial may be removed every six (6) months and the mechanism cleaned, oiled, and carefully inspected for any obvious damage. Refer to Figure 4-2, Lubrication Chart.

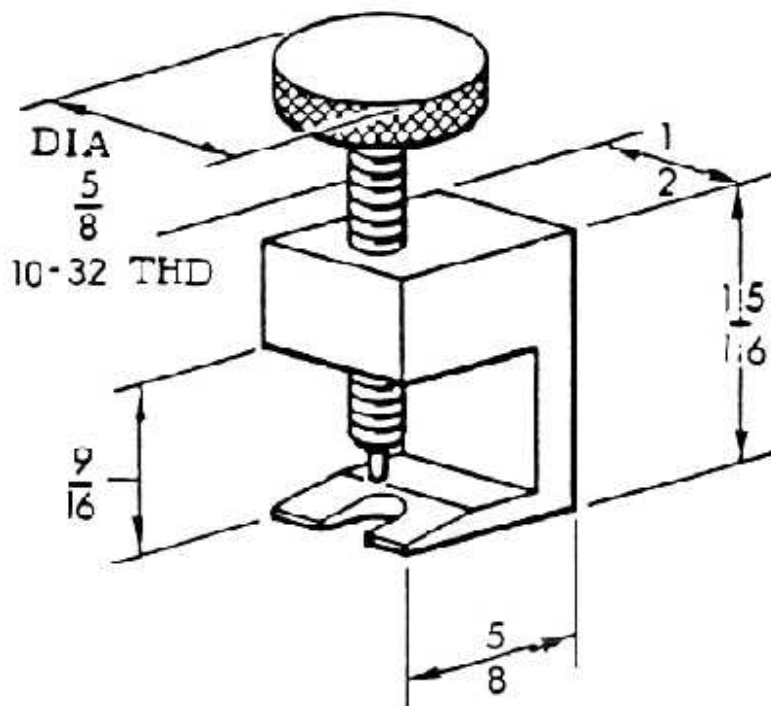
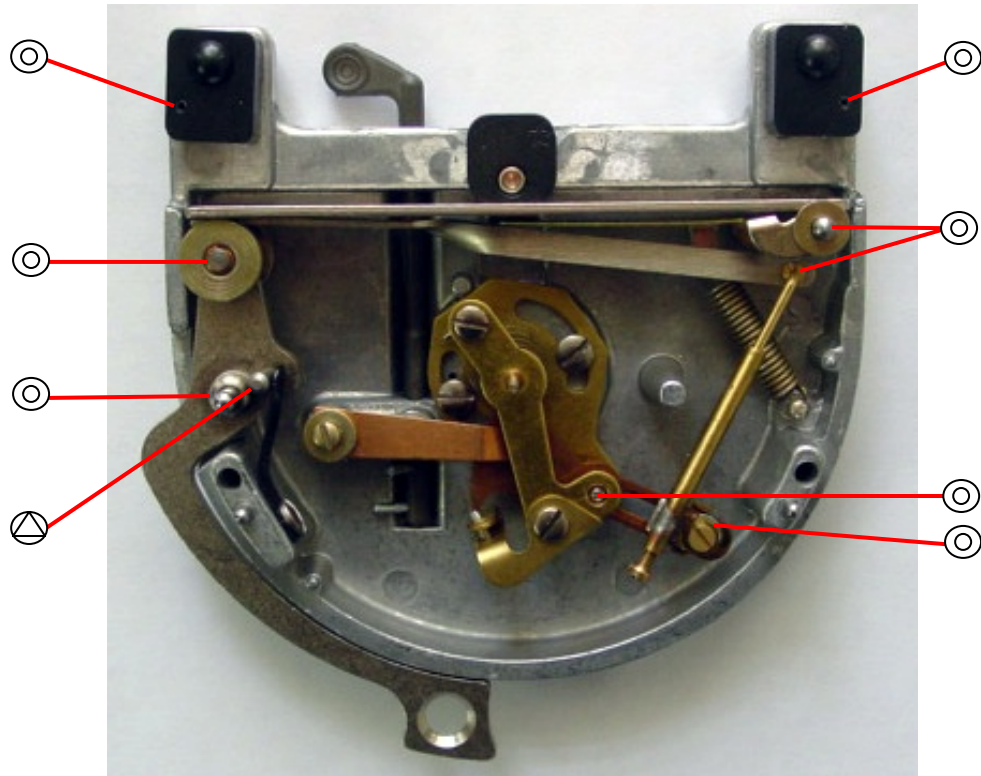

Figure 4-1. Handjack (P/N: T5-AT-1)



LEGEND

- ⊙ High-Grade Hydraulic Oil
- ⊠ Dow Corning Grease #33 fluid type or equivalent to NATO type G-395 fluid type per MIL-PRF-81322

Figure 4-2 Lubrication Chart

- 4-4. The recommended recalibration interval is every (12) twelve months. Always check the tensiometer when it accidentally dropped down, and recalibrated if it is necessary. For calibration procedures, refer to Section VI.

MAINTENANCE

- 4-5. To clean, remove the cover, pointer assembly, and dial. Wash the case and internal mechanism with cleaning solvent. Low air pressure may be used to dry the internal mechanism.

CAUTION

UNDER NO CIRCUMSTANCES SHALL HIGH PRESSURE AIR BE USED, AS THIS WILL DAMAGE THE HAIRSPRING OF THE INTERNAL MECHANISM.

- 4-6. If the internal mechanism is extremely dirty it should be cleaned thoroughly by disassembling, as outlined in Section V, each part washed individually in cleaning solvent, dried, and lubricated.

4-7. LUBRICATION. After making certain the internal mechanism is clean and dry, lubricate in accordance with the lubrication chart (See Figure 4-2). Apply oil and grease with the end of a jeweler's screwdriver or flattened wire. Avoid excessive use of oil or grease, as this only serves to collect dirt.

SERVICE TROUBLES AND REMEDIES

4-8. Refer to Table 4-1 for troubleshooting information.

<i>TROUBLE</i>	<i>CAUSE (REFER TO FIGURE 7-1)</i>	<i>REMEDY</i>
Bent pointer assembly (5)	Overloading caused by clamping Tensiometer on a cable loaded in excess of Tensiometer calibrated range, or using wrong riser	Straighten pointed assembly and adjust it to zero in case minor overload. If mainspring leaf assembly is bent, refer to Section V for repair
Pointer assembly (5) not returning to zero.	Binding in sleeve assembly (11) due to misalignment of Linkage rod (15) in sleeve assembly or excessive dirt	Clean sleeve assembly and realign linkage rod if necessary
Sectors (42 or 43) not returning to normal position.	Sector springs (44) bent out of contact with sector pivot pin (41)	Straighten or replace sector springs
Brake lever rod (24) failing to lock or release	Screw (18) loose or brake spring (20) out of alignment	Tighten screw and, if necessary, bend spring so that it clears segment about 1/64 inch when in the unlocked position
Trigger assembly (30 thru 34 or 35) binding	Lack of lubrication on roller pin (32) or trigger spring pin (33)	If necessary, remove trigger spring pin, polish contact surface. Replace and lubricate spring pin and trigger rollers (31) as instructed in lubrication chart (See Figure 4-2)
Loose pointer assembly	Pointer assembly (5) not pressed on to spindle of movement assembly (27) far enough, or hole in pointer assembly is enlarged	Press pointer assembly tightly on spindle of movement assembly. If hole in pointer assembly is enlarged, squeeze pointer assembly bushing together slightly to ensure a press fit

Table 4-1. Troubleshooting Chart

SECTION V

DISASSEMBLY, INSPECTION, REPAIR AND REASSEMBLY

DISASSEMBLY. (See figure 7-1.)

- 5-1. Although full disassembly procedures are provided, disassemble Tensiometer only to the extent required to replace or repair the defective part.
- 5-2. Remove two case screws (1). Remove pointer assembly (5), using handjack (P/N: T5-AT-1), or equivalent, to avoid bending spindle of movement assembly (27), then lift off dial (6).
- 5-3. Remove screw (7) and slide sleeve assembly from linkage rod (15).
- 5-4. Unhook riser clip spring (12) from pin drive screw (48) and remove mainspring leaf assembly (16) and riser clip assembly (17) from mainspring pivot pin (46). Note position of clip assembly to serve as an aid during reassembly.
- 5-5. Remove screw (18), washer (19), brake spring (20), brake plunger spring (21) and brake plunger (22).
- 5-6. If it is necessary to remove brake lever rod (24), first remove groove pin (23) then brake lever rod will slide out.

Note

Before removing screws (25), mark their position on the movement assembly (27) so that when reassembled, movement assembly will be located in its original position.

- 5-7. Remove screws (25), washers (26), and then carefully remove movement assembly (27).
- 5-8. Remove screw (28) and trigger spring (29), then remove lever assembly (34 or 35) from case.
- 5-9. If it is necessary to remove sector assemblies (42 and 43), press out pins (41) then removes sector assemblies and sector springs (44).

Note

Complete disassembly and overhaul of the Tensiometer should not be necessary, except where Tensiometer has been used over a long period of time without routine maintenance, or where accidents and/or service operating conditions have resulted in major damage to the unit.

INSPECTIONS AND REPAIR (See Figure 7-1.)

- 5-10. Perform the inspection and repair procedures in accordance with the following instructions. It is suggested a strong light and magnification be used when performing the inspection procedures.
- a. Inspect all parts for nicks, scratches, corrosion, or cracks.
 - b. Check case assembly (49) for loose pins (41, 45, and 46). Pin should be a tight fit in case assembly. If pins are slightly loose, swaging the metal around the hole with a hollow punch may tighten them. Make certain when swaging that pins are in vertical alignment. If bearing surface of pin are badly marred, replace pins.
 - c. Inspect all threaded parts for worn or damaged threads, especially in cover (2) and case (49). Chase or tap any minor imperfections of threads, providing function and fit of threads are in no way impaired. If threads are stripped or badly damaged, replace the applicable part.
 - d. Check arm of main spring leaf assembly (16) for alignment. The free end should be slightly above the center of the main spring leaf assembly bearing and should clear the bearing by approximately 0.010 inch. Linkage rod (15) should fit freely into arm with sufficient side play to permit easy alignment with sleeve assembly (11) when parts are assembled. If rivets in end of main spring leaf assembly are loose, tighten or replace.
 - e. Check fit of fingers of riser clip assembly (17) on lug of main spring leaf assembly. There shall be no binding. If there is any binding, fingers of riser clip assembly may be bent slightly to eliminate the binding. This condition is also applicable when parts are assembled in case (49).
 - f. Inspect trigger rollers (31) for freedom of rotation on roller pin (32). If any binding is evidenced, remove roller rings (30), then remove trigger rollers (31). Clean and polish roller pin (32) and holes in trigger rollers (31).
 - g. Check roller pin (32) and trigger spring pin (33) for a tight secure fit in lever assembly (34 or 35). Swage areas around pins if necessary to produce a tight secure fit.
 - h. Inspect action of segment and pinion of movement assembly (27). Action should be smooth with no binding. Check all screws in the movement assembly for tightness. If zero adjustment screw in segment stop of movement is loose, removing the screw, bending the segment stop ears closer together and replacing screw may tighten it. If any further or obvious damage of the movement assembly is evidenced it should be returned to the manufacturer for repair or replacement.

REASSEMBLY (See figure 7-1.)

- 5-11. Reassemble the Tensiometer in the same order as the key index number assigned to the exploded view illustration, noting the following:
- a. Attach sectors (42 and 43), making certain that stop pins properly engage sector springs (44).
 - b. Install lever assembly (34 or 35) and trigger spring (29). Secure trigger spring (29). Secure trigger spring in position with screw (28).
 - c. Install movement assembly (27) in case (49) and retain in position with screw (25) and washer (26).
 - d. Insert brake rod lever (24) through hole in case (49), then install groove pin (23) in brake rod lever.
 - e. Assemble brake plunger spring (21) and brake spring (20) into case, and secure in position with screw (18) and washer (19).
 - f. Place riser assembly clip (17) and main spring leaf assembly (16) on main spring pivot pin (46). Attach one end of riser clip spring (12) to riser clip assembly, and secure the other end of riser clip spring to case with drive screw (48).
 - g. Locate linkage rod (15) in hole provided in main spring leaf assembly (16), followed by spring (13) and washer (14). Slide sleeve assembly (11) on to linkage rod (15) and secure to movement assembly (27) with channel nut (9), washer (8), and screw (7).
 - h. Position dial (6) in place, then install pointer assembly (5) on spindle of movement assembly (27), using handjack.
 - i. Before completion of assembly, adjust range and, if necessary, make adjustments. Refer to Section VI.
 - j. Place glass (3) followed by bezel (4) in cover (2). Place cover on case (49) and secure in place with screws (1).
 - k. Recalibrate as necessary. Refer to Section VI.

SECTION VI

CALIBRATION TEST PROCEDURES

GENERAL

- 6-1. Testing and adjustment procedures require that a satisfactory calibration device be available. One such device is shown in figure 6-1.

RANGE ADJUSTMENT (See Table 6-1)

- 6-2. Each Tensiometer shall be adjusted prior to its original calibration to give the maximum range setting. Maximum range setting in this instance means the highest and lowest dial reading on the Tensiometer to utilize the full dial scale range of 0 to 100. The Range Adjustment Table, Table 6-1, shows the cable size and load in pounds, which will give the high and low readings. For example, on Model T5-2002-104, set the high readings between 93 and 96 (typically) on the dial of the Tensiometer, utilizing a 1/4-inch diameter cable with a tension load of 200 pounds. If the Tensiometer range is adjusted correctly, then the low reading value on the dial should be between 9 and 12, utilizing a 1/16-inch diameter cable with a tension load of 30 pounds.

Note

If a considerable amount of range adjustment work is to be performed, it will expedite the operation to obtain an extra dial, Part Number T559, and cut away the center of the dial so that just the scale figures remain. The range adjustment can then be made without having to remove the pointer assembly and the dial each time.

- 6-3. Range adjustment is accomplished by the following procedure, with the assumption that a cut-away dial is being used. If a cut-away dial is not being used, then the pointer assembly and dial will have to be removed each time an adjustment is required.
- a. Install cut-away dial and pointer assembly. Rotate pointer in a clockwise direction approximately 2-1/4 turns to apply a load to hairspring in the movement assembly.
 - b. Turn zero adjusting screw (figure 2-1) until it just contacts segment of movement assembly.
 - c. If pointer assembly is not reading zero, remove pointer assembly and reposition so that it reads zero.
 - d. Take readings at the high and low range points as indicated in the Range Adjustment Table, Table 6-1.
 - e. If the high and low readings are both two to three divisions of the scales, high or low, the range may be brought within limits specified in the Range Adjustment Table, Table 6-1, by adjusting screw (10, figure 2-1). Turning the screw clockwise raises the range (moves the pointer counterclockwise on the dial), and turning the screw counterclockwise lowers the range (moves the pointer clockwise on the dial).

WARNING:

Do not overload the instrument – that is, permit the Pointer to go beyond the “100” mark on the dial. When first applying to a tight cable, close the Trigger slowly and watch the Pointer to be sure it will not go above the “100” mark when the load is fully applied. Permanent damage may be done to the instrument when it is overloaded.

- f. If the range spread is incorrect, that is, the high reading is too high and the low reading is too low, it may be adjusted by adjusting the position of sleeve assembly (11, figure 2-1) where it attaches to the slotted arm of the movement. Loosen screw (7). With screw (7) loose the sleeve assembly can be moved in toward the movement if the range spread is too small (i.e., if high reading is low and low reading is high), or away from the movement if the range spread is too great (i.e., the high is too high and the low reading too low). This is a delicate adjustment requiring only a small amount of movement and should be made carefully. When the adjustment has been made and the range spread is within limits, tighten screw (7).
- g. When adjustment is complete, reset pointer assembly if necessary, to zero with the zero adjusting screw. Remove pointer assembly and cut-away dial. Replace normal dial and pointer assembly, making certain that pointer assembly is on the zero mark.

Note:

Due principally to the uneven surface of the stranded cables, slight variations in readings may occur on the same cable at the same tension. If closest possible accuracy is desired take two or three reading at slightly different locations on the test area of the cable and average them. It is considered a unit to be ‘out of calibration’ when the average reading is more than (+/-) 2 pts against the charted readings in the calibration card.

TABLE 6-1. RANGE ADJUSTMENT TABLE

T5-2001-104-00	401-1C-2	#1	1/8	200	93-96	#1	1/16	30	9-12
T5-2002-101-00	402-1J-2	#3	1/4	150	88-95	#1	1/16	10	5-7
T5-2002-103-00	402-1B-2	#3	1/4	250	93-96	#1	1/16	30	9-12
T5-2002-104-00	402-1C-2	#3	1/4	300	93-96	#1	1/16	30	9-12
T5-2002-104A-00	N/A	#3	1/4	300	93-96	#1	1/16	30	9-12
T5-2002-105-00	402-1D-2	#3	1/4	400	93-96	#1	1/16	30	7-10
T5-2002-301-00	Dual Calibration*	#3	45 CWT	150	88-95	#1	3 CWT	10	5-7
T5-2002-304-00	Dual Calibration*	#3	45 CWT	300	80-85	#1	3 CWT	30	10-13
T5-2002-401-00	Dual Calibration*	#3	70 CWT	150	94-96	#1	5 CWT	10	5-7
T5-2004-113-00	404-1K-2	#1	1/8	100	75-79	#1	1/16	10	5-7
T5-2006-115-00	N/A	#1	1/16	60	74-78	#1	1/16	5	7-10
T5-8002-104B-00	N/A	#3	1/4	300	94-96	#1	1/16	10	4-7
T5-8002-105-00	N/A	#3	1/4	400	94-96	#1	1/16	30	7-10
T5-8002-211-00	N/A	#2	1/8	350	91-96	#2	1/16	35	8-11
T5-8002-401-00	Dual Calibration*	#3	70 CWT	150	94-96	#1	5CWT	10	5-8
T5-8003-106-00	N/A	#2C	1/4	600	94-96	#2C	3/16	40	6-9
T5-8003-107-00	N/A	#2C	1/4	800	94-96	#2C	3/16	100	5-8
T5-8003-108-00	N/A	#2C	1/4	1000	94-96	#2C	3/16	200	7-10
T5-8003-209-00	N/A	#4	3/8	400	91-96	#4	1/4	200	9-12
T5-8005-109-00	N/A	#2C	1/4	1300	94-96	#2	3/16	250	8-11
T5-8005-110-00	N/A	#2C	1/4	1600	94-96	#2	3/16	300	8-11
T5-8005-111-00	N/A	#2C	1/4	2000	94-96	#2	3/16	500	9-12
T5-8008-106-00	N/A	#3	1/4	600	94-96	#2	1/8	40	4-7
T5-8008-306-00	Dual Calibration*	#3	1/4	600	94-96	#2	1/8	40	9-12
T5-8103-406-00	Dual Calibration*	#3B	1/4	1400	96-98	#2C	3/16	40	6-9
T5-8203-108-00	N/A	#3B	3/8	1000	92-95	#3B	3/8	200	45-48

* Dual calibration are those models that reads on both type of cables (STD & CWT British). Refer to table 6-2 for further information.

CALIBRATION

- 6-4. The Calibration Data Sheet, Table 6-2, shows the correct selection of cables and riser sizes used on each Tensiometer model. Particular care must be taken to be sure risers are used as indicated. Dead weight tests could be performed as follows:

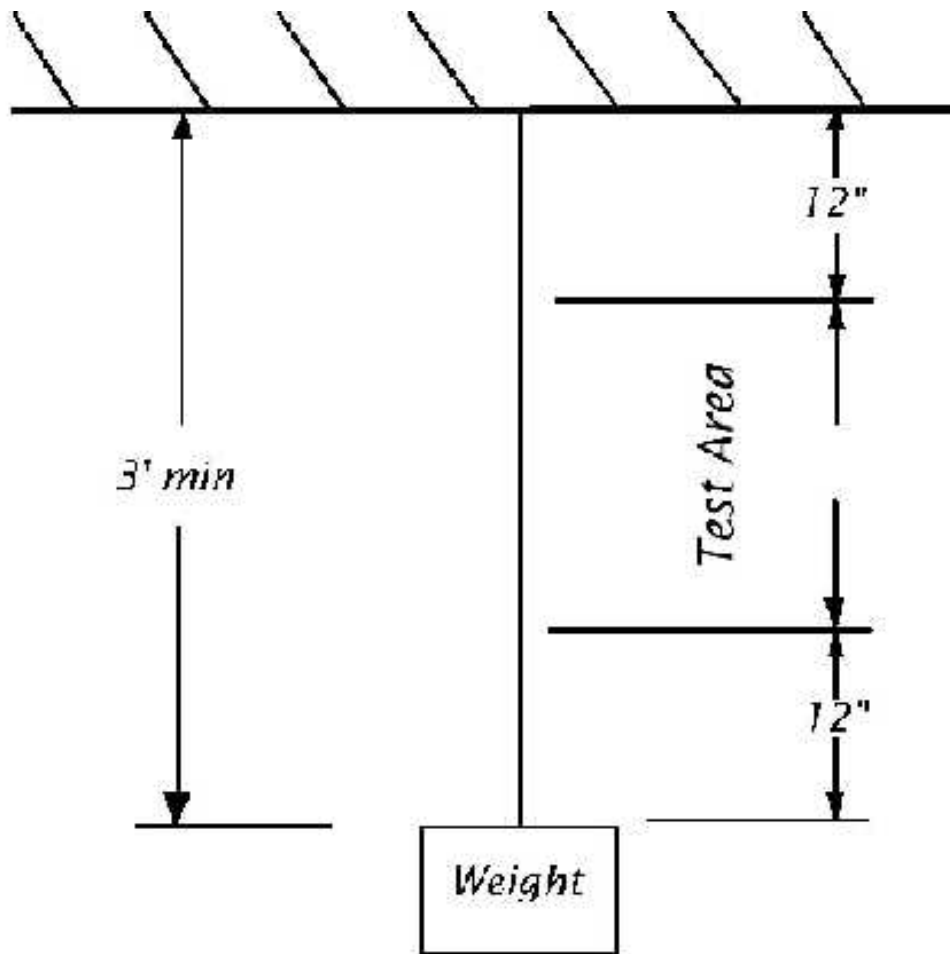

NOTE: The weight should be guided or restrained in an appropriate manner to prevent rotating or swinging.

Figure 6-1. T5 Tensiometer Dead Weight, Calibration Set-up

Note:

The attitude of the indicator does not affect the readings – i.e., it makes no difference whether the Indicator is in vertical or horizontal attitude, or at any point between these positions.

- a. Fasten a section of cable from a beam or other support. The cable should be the same size as the cable intended to be checked or used, and should be at least 3 feet long. (See figure 6-1.)
- b. Hang a certainly known weight to the free end of the cable. The weight should be at the low limit of the required test area.
- c. Take five readings at different positions on the hanging cable, but no closer than 12 inches to either the fixed end or the weighted end of the cable. Record the known weight and the average of the five readings.
- d. Increase the weight and repeat step c. Repeat this procedure as often as necessary to cover the required test range. The result will be a list of weights and corresponding T5 Tensiometer readings, which can be used as a valid calibration chart. See Figure 3-3 for a example of a completed calibration chart.
- e. If the successive weights of step d are close enough, straight-line interpolation may be used for intermediate values. The following chart gives recommended check intervals related to the calibration range for most conditions.

Calibration Range (Lbs)	Check Weight Intervals (LBS)
0 – 100	10
100 – 200	25
200 – 400	50
400 – 1000	100
1000 – Up	200

- 6-5.** For in-plant test purposes, cables as close as possible to the main diameter are desirable. However, during vendor testing and calibration, different cable runs and possible pre-stretching may be encountered. Therefore, readings may vary slightly from those indicated on the calibration card. If this variation is considered critical, it is suggested that “*Dead Weight Calibration*” be performed, using the same cable as that to be used in the aircraft. This procedure is outlined in paragraph 6-4, steps a through e. The maximum tolerance or permissible error for the charted reading values against actual average readings values is (+/-) 2 points using accurate known weights.

Note

For specifications on the aircraft control cables, commonly known as ‘wire rope’ cables, please refer to the latest revision of the MIL-DTL-83420, Type I in either A or B composition, General Specification for Wire Ropes, Flexible for aircraft control.

TABLE 6-2. Calibration Data Table

CALIBRATION DATA TABLE							
TYPE 5 CABLE TENSIO METER - STANDARDS MODELS							
MODEL No.	OLD MODEL No.	FOR USE ON CABLE	RANGE IN LBS.	READING INTERVAL IN LBS.	RISER USED	REMARKS	CALIBRATION CARD USED
T5-2001-101-00	401-1J-2	1/16, 3/32, 1/8	10-100	5 (10-50)	#1	NSN: 6635002930399 U.S.A.F.: C5	T594-101
		5/32, 3/16	15-150	10 (50-150)	#2C		
T5-2002-101-00	402-1J-2	1/16, 3/32, 1/8	10-100	5 (10-50)	#1	NSN: 6635002930400 U.S.A.F.: C5	T594-101
		5/32, 3/16	15-150	10 (50-150)	#2C		
		7/32, 1/4	25-150	10 (50-150)	#3		
T5-2001-102-00	401-1A-2	1/16, 3/32, 1/8	30-160	10 (30-160)	#1	U.S.A.F.: C5	T593-102
		5/32, 3/16	30-200	10 (30-200)	#2C		
T5-2002-103-00	402-1B-2	1/16, 3/32, 1/8	30-160	10 (30-160)	#1	U.S.A.F.: C5	T593-103
		5/32, 3/16	30-200	10 (30-200)	#2C		
		7/32, 1/4	30-250	10 (30-250)	#3		
T5-2001-104-00	401-1C-2	1/16, 3/32, 1/8	30-200	10 (30-200)	#1	U.S.A.F.: C5	T595-104
		5/32, 3/16	30-300	20 (200-300)	#2C		
T5-2002-104-00	402-1C-2	1/16, 3/32, 1/8	30-200	10 (30-200)	#1	NSN: 6635005082700 U.S.A.F.: C5	T595-104
		5/32, 3/16	30-300	20 (200-300)	#2C		
		7/32, 1/4	30-300	20 (200-300)	#3		
T5-2002-104A-00	N/A	1/16, 3/32	30-300	10 (30-200)	#1	N/A	T594-104A
		5/32, 3/16, 1/8	30-300	20 (200-300)	#2C		
		7/32, 1/4	30-300	20 (200-300)	#3		
T5-2002-105-00	402-1D-2	1/16, 3/32, 1/8	30-200	10 (30-200)	#1	N/A	T594-105
		5/32, 3/16	30-400	20 (200-400)	#2C		
		7/32, 1/4	30-400	20 (200-400)	#3		
T5-2004-113-00	404-1K-2	1/16, 3/32, 1/8	10-100	5 (10-100)	Fixed #1	NSN: 6635002318511	T594-113
T5-2006-115-00	N/A	1/16	5-60	5	Fixed #1	N/A	T615-115
				2 (6-22)			
				5 (25-40)			
				10 (50-60)			

(Sheet 1 of 3)

CALIBRATION DATA TABLE							
TYPE 5 CABLE TENSIO METER - STANDARDS MODELS							
MODEL No.	OLD MODEL No.	FOR USE ON CABLE	RANGE IN LBS.	READING INTERVAL IN LBS.	RISER USED	REMARKS	CALIBRATION CARD USED
T5-2002-301-00	N/A	-	-	-	-	ALSO READ ON:	T594-101 & T594-301B
		3, 5, 10 (CWT)	10-100	5 (10-50)	#1	1/16, 3/32, 1/8	
		15, 25 (CWT)	15-150	10 (50-150)	#2C	5/32, 3/16	
		35, 45 (CWT)	25-150	10 (50-150)	#3	7/32, 1/4	
T5-2002-304-00	N/A	-	-	-	-	ALSO READ ON:	T595-104 & T594-304B
		3, 5, 10 (CWT)	30-200	10 (30-200)	#1	1/16, 3/32, 1/8	
		15, 25 (CWT)	30-300	20 (200-300)	#2C	5/32, 3/16	
		35, 45 (CWT)	30-300	20 (200-300)	#3	7/32, 1/4	
T5-2002-401-00	N/A	1/16, 3/32, 1/8	10-100	5 (10-50)	#1	N/A	T594-101 & T610-401B
		5/32, 3/16	15-150	10 (50-150)	#2C		
		7/32, 1/4	25-150		#3		
		5, 10 (CWT)	10-100	5 (10-50)	#1		
		15 (CWT)	15-150	10 (50-150)	#2C		
		20, 25 (CWT)	15-150		#2C		
		70 (CWT)	25-150		#3		
T5-8002-104B-00	N/A	1/16	10-300	For All Cables	#1	NSN: 6635012447810	T617-104B
		3/32, 1/8	10-300	5 (10-50)	#2		
		5/32, 3/16	10-300	10 (60-100)	#2C		
		7/32, 1/4	10-300	20 (120-300)	#3A		
T5-8002-105-00	N/A	1/16, 3/32, 1/8	30-200	10 (30-200)	#1	NSN: 6635005276507	T594-105
		5/32, 3/16	30-400	20 (200-400)	#2C		
		7/32, 1/4	30-400	20 (200-400)	#3		
T5-8003-106-00	N/A	3/16, 7/32, 1/4	40-600	20 (40-300)	#2C	SET HIGH READING ON 1/4 CABLE, SEE TABLE 6-1	T597-106
		5/16	40-600	50 (300-600)	#3A		
T5-8008-106-00	N/A	1/8, 5/32	40-600	20 (40-600)	#2	U.S.A.F.: C6	T596-106
		3/16	40-600	20 (40-600)	#2C		
		1/4	40-600	20 (40-600)	#3		
T5-8003-107-00	N/A	3/16, 7/32, 1/4	100-800	50 (100-800)	#2C	SET HIGH READING ON 1/4 CABLE, SEE TABLE 6-1	T597-107
		5/16	100-800	50 (100-800)	#3A		
T5-8203-108-00	N/A	3/8	200-1000	50 (200-1000)	#3B	NSN: 6635009056213	T597-8203-108
T5-8003-209-00	N/A	1/4, 5/16, 3/8	200-400	25 (200-400)	#4	NSN: 1710005941376	T5178-211
T5-8002-211-00	N/A	1/16, 3/32, 1/8	35-350	5 (35-100)	#2	N/A	T594-211
		1/16, 3/32, 1/8	35-350	25 (100-350)	#2		

(Sheet 2 of 3)

CALIBRATION DATA TABLE

TYPE 5 CABLE TENSIO METER - STANDARDS MODELS

MODEL No.	OLD MODEL No.	FOR USE ON CABLE	RANGE IN LBS.	READING INTERVAL IN LBS.	RISER USED	REMARKS	CALIBRATION CARD USED
T5-8003-108-00	N/A	3/16, 7/32, 1/4	200-1000	50 (200-1000)	#2C	SET HIGH READING ON 1/4 CABLE; SEE TABLE 6-1	T597-108
		5/16	200-1000	50 (200-1000)	#3A		
T5-8005-109-00	N/A	3/16	250-1300	50 (250-1300)	#2	SET HIGH READING ON 1/4 CABLE; SEE TABLE 6-1	T597-109
		7/32, 1/4	250-1300	50 (250-1300)	#2C		
		5/16	250-1300	50 (250-1300)	#3A		
T5-8005-110-00	N/A	3/16	300-1600	50 (300-1600)	#2	NSN: 6635005301130; SET HIGH READING ON 1/4 CABLE; SEE TABLE 6-1; U.S.A.F.: C7	T597-110
		7/32, 1/4	300-1600	50 (300-1600)	#2C		
		5/16	300-1600	50 (300-1600)	#3A		
T5-8005-111-00	N/A	3/16	500-2000	50 (500-1000)	#2	SET HIGH READING ON 1/4 CABLE; SEE TABLE 6-1	T597-111
		7/32, 1/4	500-2000	100 (1000-2000)	#2C		
		5/16	500-2000	100 (1000-2000)	#3A		
T5-8008-306-00	N/A	-	-	-	-	ALSO READ ON:	T596-106 & T596-306
		10, 15 (CWT)	40-600	20 (40-600)	#2	1/8, 5/32	
		25 (CWT)	40-600	20 (40-600)	#2C	3/16	
		45 (CWT)	40-600	20 (40-600)	#3	1/4	
T5-8002-401-00	N/A	1/16, 3/32, 1/8	10-100	5 (10-50)	#1	N/A	T594-101 & T610-401B
		5/32, 3/16	15-150	10 (50-150)	#2C		
		7/32, 1/4	25-150		#3		
		5, 10 (CWT)	10-100	5 (10-50)	#1		
		15 (CWT)	15-150	10 (50-150)	#2C		
		20, 25 (CWT)	15-150		#2C		
T5-8103-406-00	N/A	3/16, 7/32, 1/4	40-600	20 (40-300)	#2C	N/A	T597-406 & T5069-406
		5/16	40-600	50 (300-600)	#3A		
		5, 10, 15 (CWT)	25-125	10 (25-125)	#1		
		20, 25 (CWT)	25-125	10 (25-125)	#2		
		25 (CWT)	150-250	25 (150-250)	#2		
		45 (CWT)	200-1400	50 (200-600)	#3A		
		45 (CWT)	200-1400	100 (600-1400)	#3A		
		80 (CWT)	200-600	50 (200-600)	#3A		
		80 (CWT)	600-1400	100 (600-1400)	#3B		

(Sheet 3 of 3)

<i>RISER</i>		<i>#1</i>			<i>#2C</i>		<i>#3</i>																		
<i>LOAD</i>	<i>CABLE</i>	<i>1/16</i>	<i>3/32</i>	<i>1/8</i>	<i>5/32</i>	<i>3/16</i>	<i>7/32</i>	<i>1/4</i>																	
10 lbs-tension																									
15																									
20																									
25																									
30																									
35																									
40																									
45																									
50																									
60																									
70																									
80																									
90																									
100																									
110																									
120																									
130																									
140																									
150																									
160																									
170																									
180																									
190																									
200																									
210		---	---	---																					
220		---	---	---																					
230		---	---	---																					
240		---	---	---																					
250		---	---	---																					
260		---	---	---																					
270		---	---	---																					
280		---	---	---																					
290		---	---	---																					
300		---	---	---																					
320		INSTRUMENT NO.																							
340					MODEL:																				
350								CALIBRATED BY:																	
360											DATE:														
370														REMARKS:											
380																									
390																									
400																									

Figure 6-2. Calibration Work Sheet

SECTION VII

ILLUSTRATED PARTS BREAKDOWN

GENERAL

- 7-1. This Illustrated Parts Breakdown lists and describes the parts for Cable Tensiometer, Pacific Type T5, manufactured by OPTI Manufacturing Corp., Luquillo, Puerto Rico 00773. (Manufactured in the past by Pacific Scientific, Kin-Tech Division.)
- a. Index numbers on the exploded view are numerically arranged in the Figure and Index No. Column of the parts list.
 - b. The Part Number Column contains part numbers only. These part numbers are used exclusively to identify parts.
 - c. The Description Column contains the complete description of each part, with dimensions if necessary, to identify the part.
 - d. The quantities listed for component parts in the Units per Assy. column of the Illustrated Parts Breakdown are the total quantities used at the location indicated. Quantities listed for component parts, indented under the subassemblies, are the quantities used per subassembly; therefore, the quantities specified are not necessarily the total used per equipment.
- 7-2. **USABLE ON CODE.** Coding is used only where more than one equipment is listed in the same parts list. An example of the letter symbols used is at the heading of each parts list. Part variations are indicated by a letter symbol in the Usable on Code column. Blank spaces in the Usable on Code column indicate the part is used in all equipment covered by the Illustrated Parts Breakdown.
- 7-3. **PART NUMBERING SYSTEM.** For convenient reference, the 28 assemblies are covered in two series, T5-2000 and T5-8000. The first numeral after the first dash in the part number determines the series to which that assembly belongs. For example, T5-2002-101-00 belongs to the T5-2000 series. The significance of the series numbers is that all assemblies in each series are made up of the same parts. The only difference between assemblies within a series is in the range and calibration, details of which are explained in Table 6-2.

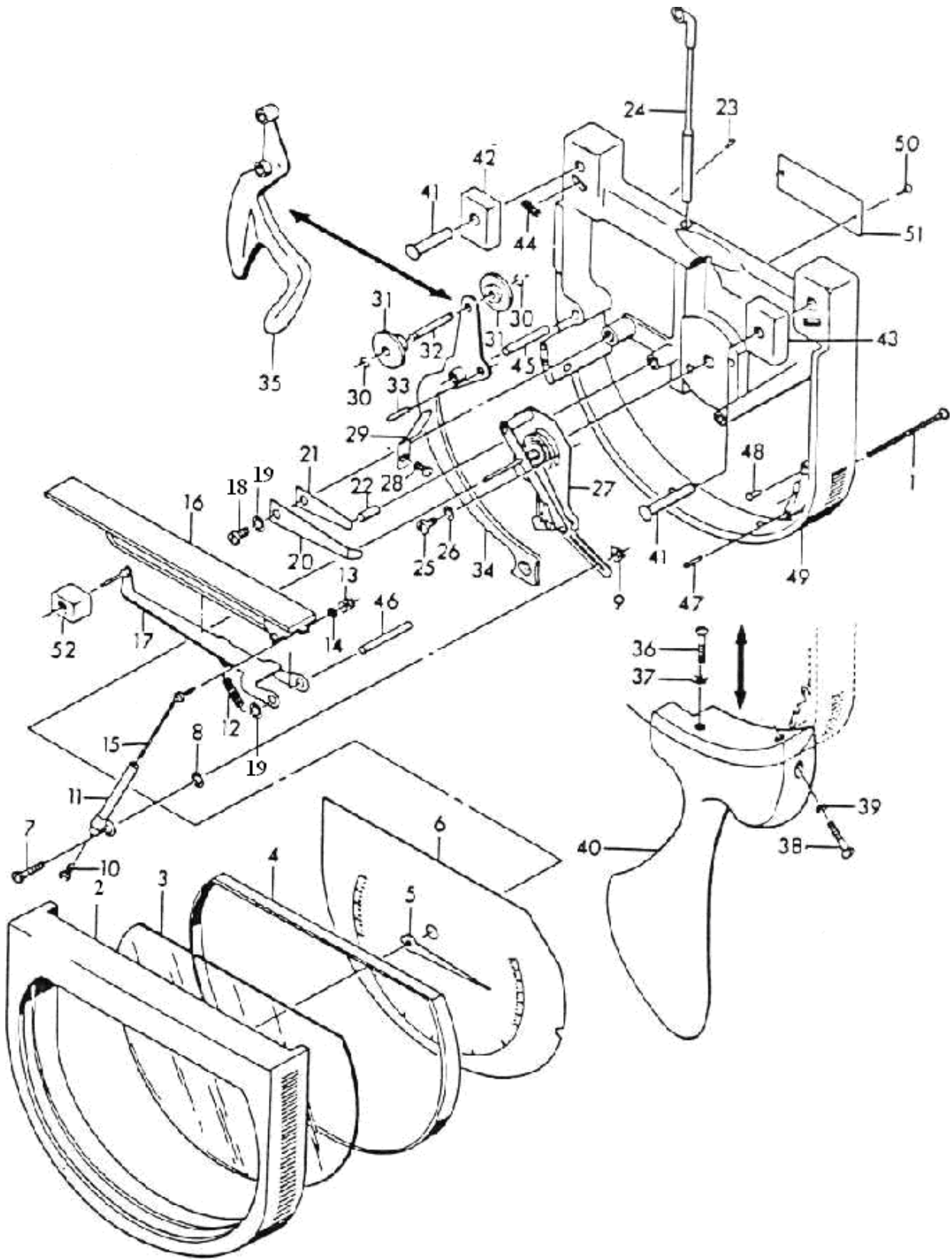

Figure 7-1. T5 Tensiometer

FIG. & INDEX NO.	PART NO.	DESCRIPTION	UNITS PER ASSY	USABLE ON CODE
	T5-2001-101-00	CABLE TENSIO METER	REF	A
	T5-2001-102-00	CABLE TENSIO METER	REF	A
	T5-2001-104-00	CABLE TENSIO METER	REF	A
	T5-2002-101-00	CABLE TENSIO METER	REF	A
	T5-2002-103-00	CABLE TENSIO METER	REF	A
	T5-2002-104-00	CABLE TENSIO METER	REF	A
	T5-2002-104A-00	CABLE TENSIO METER	REF	A
	T5-2002-105-00	CABLE TENSIO METER	REF	A
	T5-2002-301-00	CABLE TENSIO METER	REF	A
	T5-2002-304-00	CABLE TENSIO METER	REF	A
	T5-2002-401-00	CABLE TENSIO METER	REF	A
	T5-2004-113-00	CABLE TENSIO METER	REF	A
	T5-2006-115-00	CABLE TENSIO METER	REF	A
	T5-8002-104B	CABLE TENSIO METER	REF	B
	T5-8002-105-00	CABLE TENSIO METER	REF	B
	T5-8002-211-00	CABLE TENSIO METER	REF	B
	T5-8002-401-00	CABLE TENSIO METER	REF	B
	T5-8003-106-00	CABLE TENSIO METER	REF	C
	T5-8003-107-00	CABLE TENSIO METER	REF	C
	T5-8003-108-00	CABLE TENSIO METER	REF	C
	T5-8003-209-00	CABLE TENSIO METER	REF	C
	T5-8005-109-00	CABLE TENSIO METER	REF	C
	T5-8005-110-00	CABLE TENSIO METER	REF	C
	T5-8005-111-00	CABLE TENSIO METER	REF	C
	T5-8008-106-00	CABLE TENSIO METER	REF	B
	T5-8008-306-00	CABLE TENSIO METER	REF	B
	T5-8103-406-00	CABLE TENSIO METER	REF	C
	T5-8203-108-00	CABLE TENSIO METER	REF	D
1	COML # 0901100-06	. SCREW, Philips Oval Head No. 4-40 x 1-1/8 inch long	2	ALL
2	T569	. COVER	1	ALL
3	T561	. GLASS	1	ALL
4	T563	. BEZEL	1	ALL
5	T562	. POINTER ASSEMBLY	1	ALL
6	T559	. DIAL	1	ALL
7	T545	. SCREW	1	ALL
8	T546	. SPACER WASHER	1	ALL
9	T547	. CHANNEL NUT	1	ALL
10	COML # MS35265-4	. SCREW, Fillister Head, # 2-56 x ¼ inch long	1	ALL
11	T536	. SLEEVE ASSEMBLY	1	ALL
	T535	. . SLEEVE	1	ALL
	T5156	. . PLATE	1	ALL
12	T533	. RISER CLIP SPRING	1	ALL
	T520	. MAIN SPRING ASSEMBLY	1	A, B

FIG. & INDEX NO.	PART NO.	DESCRIPTION	UNITS PER ASSY	USABLE ON CODE
	T527	. MAIN SPRING ASSEMBLY	1	B, C, D
	T5152	. MAIN SPRING ASSEMBLY	1	C
	T614-1	. MAIN SPRING ASSEMBLY	1	A
13	T526	. . SPRING	1	ALL
14	T525	. . WASHER	1	ALL
15	T524	. . ROD LINKAGE	1	ALL
16	T5146	. . LEAF ASSEMBLY	1	C
	T522	. . LEAF ASSEMBLY	1	A, B
	T530	. . LEAF ASSEMBLY	1	B, C, D
	T613-1	. . LEAF ASSEMBLY	1	A
17	T574	. CLIP RISER ASSEMBLY	1	C
	T574-1	. CLIP RISER ASSEMBLY	1	A, B, D
	T575	. CLIP RISER ASSEMBLY	1	A
18	COML # MS35265-14	. SCREW, FILLISTER HEAD, #4-40 X 5/16 INCH LONG	1	ALL
19	AN960-4	. WASHER, FLAT	2	ALL
20	T551	. BRAKE SPRING	1	ALL
21	T554	. BRAKE PLUNGER SPRING	1	ALL
22	T553	. BRAKE PLUNGER	1	ALL
23	COML # 0913200-01	. GROOVE PIN, Type H, 1/16 " Ø x ¼" long	2	ALL
24	T531	. BRAKE LEVER ROD	1	ALL
25	COML # 0901100-04	. SCREW, Binding Head # 4-40 x 3/16" long	2	ALL
26	AN960-4	. WASHER, FLAT	2	ALL
27	T571	. MOVEMENT ASSEMBLY	1	ALL
28	COML # 0901100-04	. SCREW, Binding Head # 4-40 x 3/16" long	1	ALL
29	T552	. TRIGGER SPRING	1	ALL
	T504	. TRIGGER ASSEMBLY	1	A
	T5143	. TRIGGER ASSEMBLY	1	B, C, D
30	T507	. . RING LOCK	2	A
	T518	. . RING LOCK	2	B, C, D
31	T506	. . TRIGGER ROLLER	2	A
	T517	. . TRIGGER ROLLER	2	B, C, D
32	T505	. . ROLLER PIN	1	A
	T516	. . ROLLER PIN	1	B, C, D
33	T534	. . TRIGGER SPRING PIN	1	ALL
34	T509	. . LEVER TRIGGER	1	A
35	T5142	. . LEAF TRIGGER	1	B, C, D
36	COML # 0901100-63	. SCREW, FILLISTER HEAD, #6-32 X 3/8" LONG	1	B, C, D
37	COLM # MS35333-37	. WASHER, TOOTH LOCK #6 (AN936-A6)	1	B, C, D
38	COML # 0901100-07	. SCREW, Oval Head # 6-32 x 5/16 inch long	1	B, C, D
39	COML # AN936-C6	. WASHER, TOOTH LOCK #6 (MS35336-9)	1	B, C, D
40	T5140	. HANDLE	1	B, C, D
	T550	. CASE ASSEMBLY	1	A
	T560	. CASE ASSEMBLY	1	B
	T570	. CASE ASSEMBLY	1	C
	T602	. CASE ASSEMBLY	1	D

FIG. & INDEX NO.	PART NO.	DESCRIPTION	UNITS PER ASSY	USABLE ON CODE
41	T556	.. SECTOR PIVOT PIN	2	A, C, D
42	T538	.. LEFT HAND SECTOR ASSEMBLY	1	A, B
	T565	.. LEFT HAND SECTOR ASSEMBLY	1	C
	T601-1	.. LEFT HAND SECTOR ASSEMBLY	1	D
43	T538-1	.. RIGHT HAND SECTOR ASSEMBLY	1	A, B
	T565-1	.. RIGHT HAND SECTOR ASSEMBLY	1	C
	T601-2	.. RIGHT HAND SECTOR ASSEMBLY	1	D
44	T541	.. SECTOR SPRING	2	ALL
45	T512	.. TRIGGER PIVOT PIN	1	A
	T568	.. TRIGGER PIVOT PIN	1	B, C, D
46	T558	.. MAIN SPRING PIVOT PIN	1	ALL
47	T557	.. DIAL MOUNTING PIN	2	ALL
48	COML # AN535-0-4	.. DRIVE SCREW	1	ALL
49	T502	.. CASE	1	A
	T5144	.. CASE	1	B, C, D
50	COML # 0901100-01 (MS21318-1)	.. DRIVE SCREW, ROUND HEAD, TYPE LL, #00 X 1/8" LONG	2	ALL
51	T544	. NAMEPLATE	1	ALL
52	**T555-2	. RISER No. 1	1	**
	**T555-10	. RISER No. 2	1	**
	**T555-8	. RISER No. 2C	1	**
	**T555-6	. RISER No. 3	1	**
	**T555-4	. RISER No. 3A	1	**
	T5138-20	. CASE ASSEMBLY, Carrying	1	A
	T5138-80	. CASE ASSEMBLY, Carrying	1	B, C, D
	**	. CARD TENSIO METER, Calibration	1	ALL

- . Denotes non-subassembly parts.
- .. Denotes subassembly parts.
- * Non-procurable separately; order next higher assembly.
- ** See table 6-2, Calibration Data Table, for risers and calibration cards used with each model.

REVISION HISTORY

Previous Revision	Actual Revision	Effective Date	Change Description
5	6	10/2003	The Manual was redone to computer worksheet.
6	7	7/2006	Update Section I Introduction, Tables 6-1, 6-2 and Tensiometer part list table. Update figures 2-1, 3-1, 3-2, 3-3 & 6-2. Update sections 3-1, 3-2, 4-3, 4-4, 6-2, 6-3, 6-4 & 6-5. Add section 3-4.
7	8	3/16/2007	Add section 1-2 Warranty. Update sections 3-2 & VII.
8	9	7/3/2008	Edit Figure 4-2 Lubrication Chart, Update Table of 7-1 Figure

OPTI Manufacturing Corp.

Road 992 Km. 0.3 Luquillo Industrial Park

Luquillo, PR 00773-0559 USA

Phone: 787-889-2285 / Fax: 787-889-2805

Email: info@optimanufacturing.com

Copyright© OPTI Manufacturing Corp. All rights reserved.

For the latest revision of this manual, refer to our website

<http://www.optimanufacturing.com>